

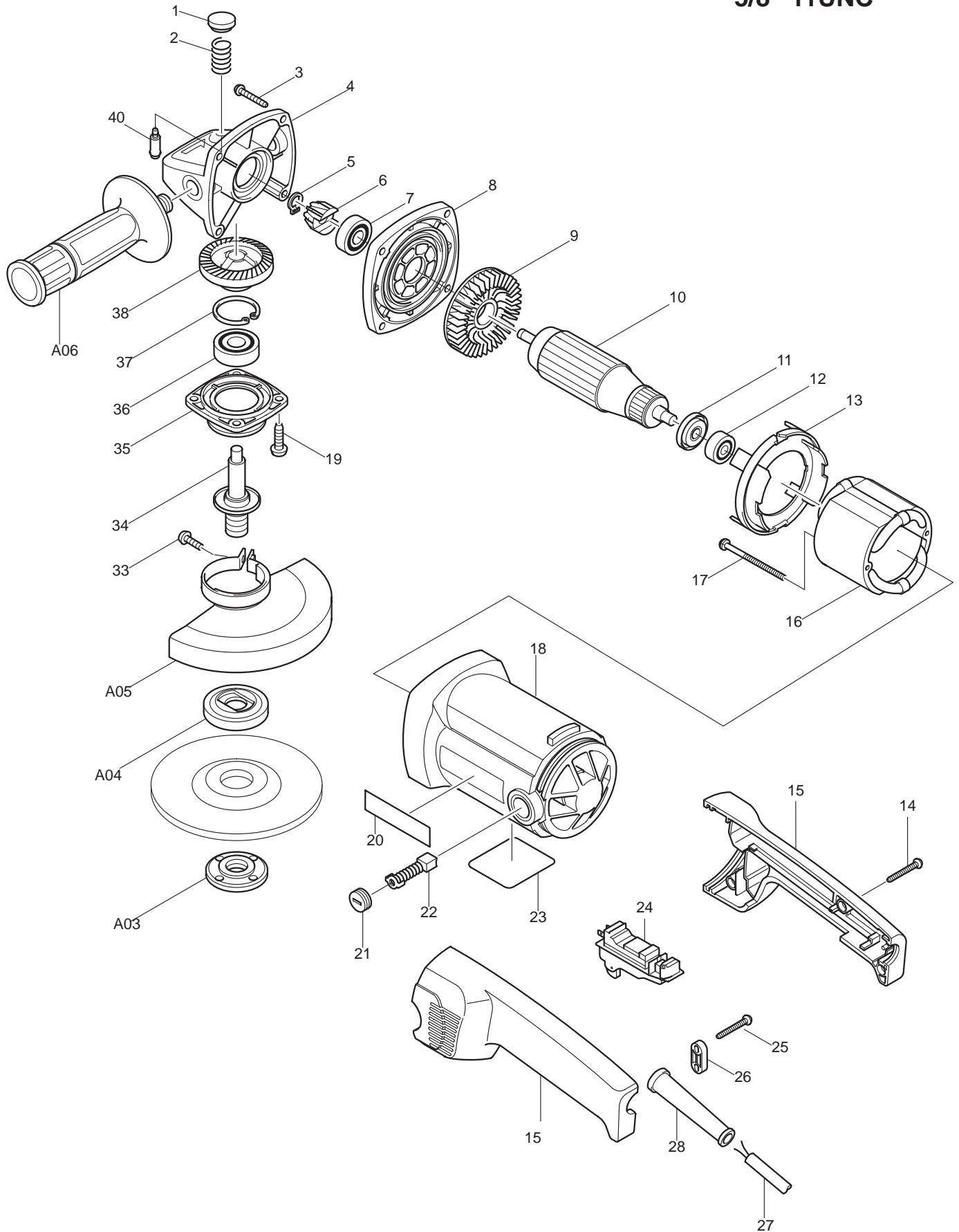

02 - 2010  
9015DB / 9015DBZ  
5" GRINDER AC/DC  
5/8" 11UNC



Item No	Type	Ref	Part No	Description	Qty	Unit
1			416449-8	PIN CAP	1	PC.
2			233089-5	COMPRESSION SPRING 12	1	PC.
3			266173-1	TAPPING SCREW 5X30	4	PC.
4			153374-9	* GEAR HOUSING COM. (OLD# 159995-5 - N/L/A)	1	PC.
5			961003-8	RETAINING RING S-7	1	PC.
6			183053-5	* SPIRAL BEVEL GEAR SET	1	PC.
		INC.	226755-1	* SPIRAL BEVEL GEAR 12	1	PC.
		INC.	226753-5	* SPIRAL BEVEL GEAR 33	1	PC.
		INC.		* Item No. 38		
7			211131-2	BALL BEARING 6001DDW	1	PC.
8			317323-2	* GEAR HOUSING COVER (OLD# 316992-6 - N/L/A)	1	PC.
9			240010-7	FAN 70	1	PC.
10			516331-2	ARMATURE ASS'Y 115V	1	PC.
		INC.		Item No. 9,11,12		
11			681644-1	INSULATION WASHER	1	PC.
12			210005-4	BALL BEARING 608DDW	1	PC.
13			416448-0	BAFFLE PLATE	1	PC.
14			265995-6	TAPPING SCREW 4X18	4	PC.
15	2		183274-9	* HANDLE SET (F/ 9015DB)	1	SET
15			183010-3	* HANDLE SET (F/ 9015DBZ)	1	SET
16			522846-9	* FIELD ASS'Y 115V	1	PC.
		INC.	654020-2	* RING TERMINAL	2	PC.
		INC.	654501-6	* CONNECTOR P-1.25	2	PC.
17			266029-8	TAPPING SCREW 5X65	2	PC.
18			183159-9	* MOTOR HOUSING (OLD# 159996-3 - N/L/A)	1	PC.
		INC.	643708-9	* BRUSH HOLDER 5-11	2	PC.
		INC.		* Item No. 20		
19	2		265096-0	* PAN HEAD SCREW M5X16	4	PC.
20			819001-5	MAKITA LABEL, ENG	2	PC.
21			643750-0	BRUSH HOLDER CAP	2	PC.
22	1		191963-2	CARBON BRUSH CB-303 2PC/SET (W/O ORIGIN) -N/L/A	1	SET
	2		194996-6	CARBON BRUSH CB-303 2PC/SET (W/ ORIGIN)	1	SET
23			852711-1	NAME PLATE 9015DB	1	PC.
24			651166-5	* SWITCH (AC/DC) (F/9015DB)	1	PC.
			651128-3	* SWITCH (AC/DC) (F/ 9015DBZ)	1	PC.
25			265995-6	TAPPING SCREW 4X18	2	PC.
26			687063-9	CORD CLAMP	1	PC.
27			664265-4	CORD WITH PLUG 2P-16-2.5M SJ	1	PC.
28			682505-8	CORD GUARD 10-90	1	PC.
33			251391-4	PAN HEAD SCREW M5X16	1	PC.
34			152573-0	SPINDLE COMPLETE	1	PC.
		INC.	344347-5	LABYRINTH RING	1	PC.
35			316991-8	BEARING BOX	1	PC.
36			211129-9	BALL BEARING 6201DDW	1	PC.
37			962151-6	RETAINING RING R-32	1	PC.
38			183053-5	* SPIRAL BEVEL GEAR SET	1	PC.
		INC.	226753-5	* SPIRAL BEVEL GEAR 33	1	PC.
		INC.	226755-1	* SPIRAL BEVEL GEAR 12	1	PC.
		INC.		* INC. 6		
40			256446-0	PIN 6	1	PC.
41			262086-4	* RUBBER RING 29 (Added)	1	PC.
42			442126-6	* GASKET (Added)	1	PC.

Item No	Type	Ref	Part No	Description	Qty	Unit
43			163434-9	* SWITCH LEVER COMPLETE (F/ 9015DB) (Added)	1	PC.
44			417313-6	* SWITCH BASE (F/ 9015DB) (Added)	1	PC.
100			652039-5	* + BINDING HEAD SCREW M3.5X6.8 (F/ 9015DB)	4	PC.
101			654037-5	* INSULATED EYE TERMINAL FT1.25-M3	4	PC.
<b><u>ACCESSORIES</u></b>						
<b>- See Catalogue or visit <a href="http://www.makita.ca">www.makita.ca</a> for optional accessory -</b>						
A01			782412-6	LOCK NUT WRENCH 28	1	PC.
A02	2		741407-B	5" DEPRESSED CENTER WHEEL A24P	1	PC.
		Opt.	A-80656	5" D.C.W GRIT 36	1	PC.
		Opt.	D-20797	5" D.C.W GRIT A24R	1	PC.
A03	3		224568-4	* LOCK NUT 5/8-45	1	PC.
A04	3		224378-9	* INNER FLANGE 45	1	PC.
A05	2		125097-9	WHEEL COVER ASS'Y	1	PC.
		INC.		Item No. 33		
A06			152492-0	GRIP 36 COMPLETE	1	PC.

**SERVICE CHANGES**

**1. Changes on Tapping Screw for securing Bearing Box to Gear Housing**

Item No.	Description	Type 1	Type 2
4	Gear Housing Com.	159995-5	153374-9
19	Screw	266027-2 (Tapping CT 5x16)	265096-0 (P.H. Screw M5x16)
	Serial No. 9015DB	~ 23698E	23699E ~
	9015DBZ has Type2 from initial production		

Above parts are completely interchangeable as a set.

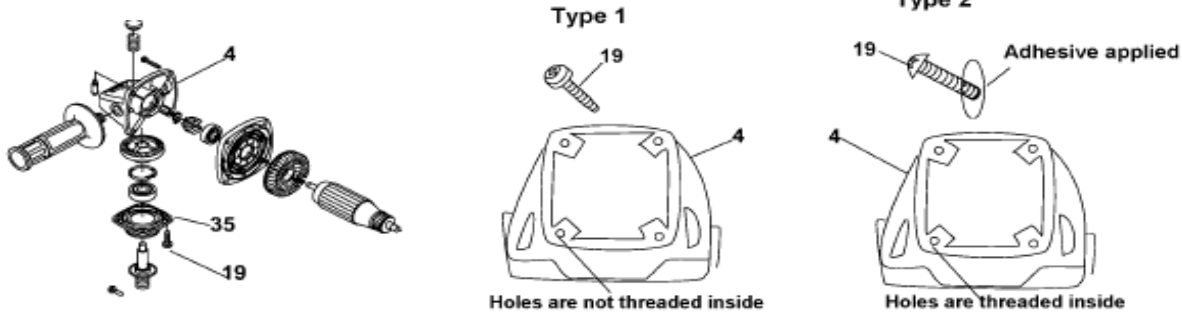

**2. Changes on Spiral Bevel Gear**

Item No.	Description	Type 1	Type 2 - 4
6 & 38	Spiral Bevel Gear Set	183017-9	183053-5
Inc.	Spiral Bevel Gear 12	226769-0	226755-1
Inc.	Spiral Bevel Gear 33	226768-2	226753-5

Above parts are completely interchangeable as a set.

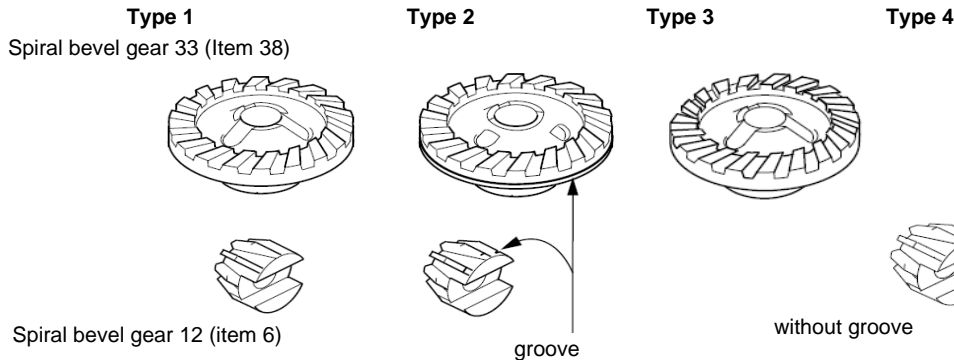

**3. Changes on Gear Housing and Addition of Rubber Ring**

Item No.	Description	Type 1	Type 2
8	Gear Housing Cover	316992-6	317323-2
41	Rubber Ring 29	-----	262086-4
42	Gasket	-----	442126-6
	Serial No. 9015DB	~ 12418E	~12419E
	9015DBZ has Type2 from initial production		

Above parts are completely interchangeable as a set.

(see illustration on next page)

**SERVICE CHANGES**

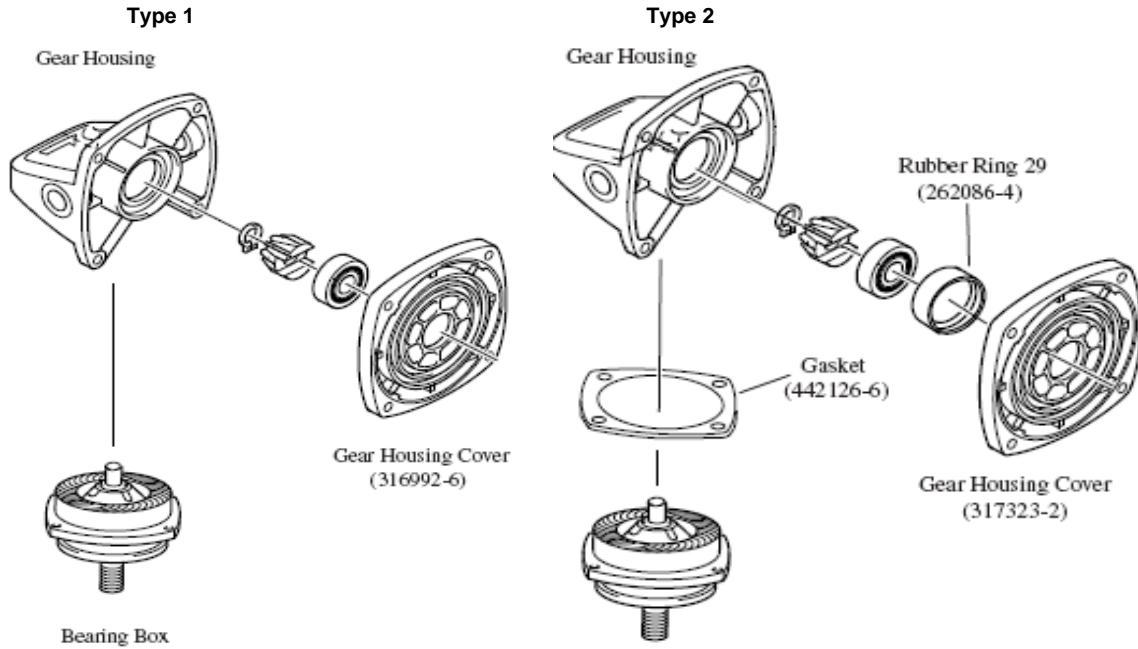

**4. Changes on Switch, Handle set, etc. (For 9015DB Only)**

Item No.	Description	Type 1	Type 2
15	Handle Set	183010-3	183274-9
24	Switch	651128-3	651166-5
43	Switch Lever Com	-----	163434-9
44	Switch Base	-----	417313-6
100	Screw	652014-1	652039-5
101	Terminal	654002-4	654037-5

Above parts are completely interchangeable as a set.

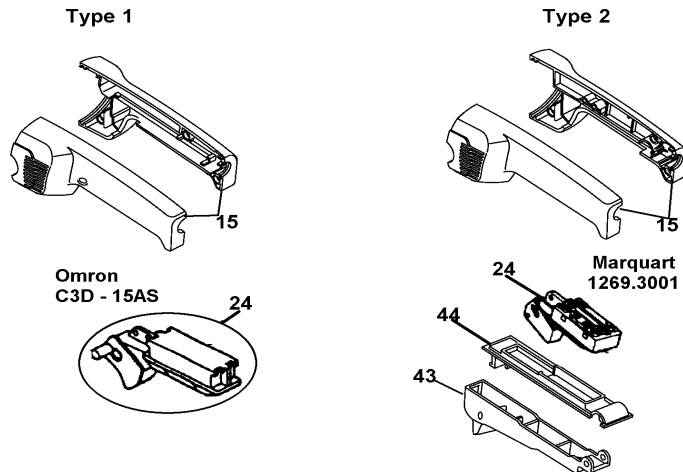

**5. Changes on Field Assy and Motor Housing Com.**

Item No.	Description	Type 1	Type 2
16	Field		522846-9
18	Motor Housing	159996-3 (N/L/A)	183159-9
	Serial No. 9015DB	~ 13818E	~ 13819E
	9015DBZ has Type2 from initial production		

Above parts are completely interchangeable as a set.

**SERVICE CHANGES**

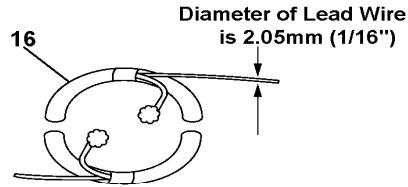
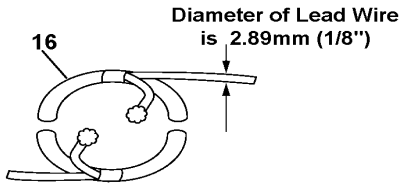

**Type 1**

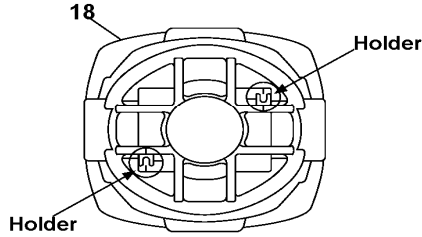

**Type 2**

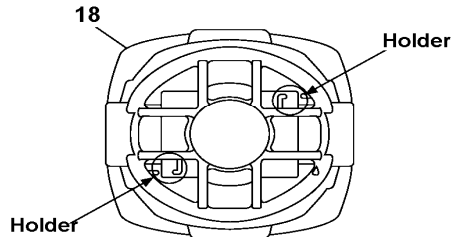

Holders on Item 18 have been modified so that the thinner lead wires can be held more firmly

**6. Changes on Lock Nut and Inner Flange**

Item No.	Description	Type 1	Type 2	Type 3
A03	Lock Nut	224509-0	224566-8 (N/L/A)	224568-4
A04	Inner Flange	224361-6	224368-2 (N/L/A)	224378-9

Above parts are completely interchangeable as a set.

**Old**

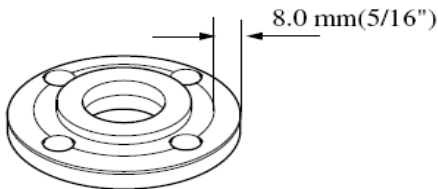

**New**

